

GHOST

Appendix

A

Notes For Machine Control

Notes for Machine Control

Protocol Support

The following tape machines/protocols are supported:

Machine/Protocol	Timecode source
MIDI Timecode master	internal
MIDI Timecode slave	MTC (Midi Time Code)
Fostex G series	MTC (Midi Time Code)
Fostex R series	MTC (Midi Time Code)
Fostex RD-8	LTC (Using Midi Machine Control)
Midi Machine Control	MTC
Midi Machine Control	LTC
MMC Open Loop	MTC
LTC Timecode Master	LTC
LTC Timecode Slave	LTC
Akai DR4	LTC & MTC (Midi Time Code)
Alesis ADAT	AI-2 (Midi Time Code)
Alesis BRC	MTC (Midi Time Code)
Sony 9-Pin	LTC
Sony 9-Pin P2 No Record	LTC
Sony UVW 1800P / TascamDA-88	LTC
Tascam DA-88	LTC (Midi Time Code)
Tascam DA-88	MTC (Midi Time Code)

All Trademarks acknowledged.

Timecode Support

The console will display the last timecode value sent by the tape machine. This means that, for some machines, when you rewind the tape the displayed timecode will be that at which the tape was stopped. This will be displayed until the tape is played again, at which point the display will update to the new value being sent.

To cope with tape dropout the **SMPTE** reader 'flywheels' for ten frames after which the timecode stops.

Control Button Support

To provide feedback to the console transport control buttons the tape machine should support 'tally' messages (i.e., feedback from the tape machine of its status). If this is not provided the console tries to interpret any timecode being sent to produce these 'tally' messages internally.

MIDI Timecode Master

The Ghost uses its own internal clock as a timecode reference for mixing. It also sends out MIDI timecode. This mode would normally be used with sequencers which can chase to MTC.

Transport Controls

Control timecode sent out by the Ghost.

Locate To Timecode

Supported. (assuming all other devices will chase to MTC)

Record Enable/Rehearse

Not supported.

Jog/Shuttle

Shuttle not supported (Use FF or REW).

Jog mode supported.

Setup Notes

Connect MIDI cable from Ghost to sequencers etc.

MIDI Timecode Slave

The Automation slaves to incoming MIDI Timecode. The transport buttons on the console indicate whether timecode is running, stopped etc. The console transport controls have no effect on the tape machine.

Transport Controls

Display only, by using timecode values returned by the tape machine.

Setup Notes

Connect MIDI cable from external MIDI Timecode source to console.

MIDI Machine Control (MTC)

This allows the Ghost to work with a tape machine which can be controlled using the generic MIDI Machine Control (MMC) protocol and which also sends the timecode as MIDI Timecode (MTC) on the same MIDI output as the MMC tallies.

Transport Controls

All supported, machine required to send back tallies.

Locate To Timecode

Supported.

Record Enable/Rehearse

Supported

Jog/Shuttle

Not supported

Setup Notes

See tape machine manual

Other Notes

Closed loop system required. Open loop users may wish to try the Alesis driver (Alesis ADAT AI-2), or the MMC Open Loop Driver.

MIDI Machine Control With LTC

This allows the Ghost to work with a tape machine which can be controlled using the generic MIDI Machine Control (MMC) protocol and which sends the timecode as SMPTE Longitudinal Timecode (LTC).

Transport Controls

All supported, machine required to send back tallies.

Locate To Timecode

Supported.

Record Enable/Rehearse

Supported

Jog/Shuttle

Not supported

Setup Notes

Connect SMPTE IN on the Ghost to the Timecode Output of the Tape Machine. Connect MIDI cables from the Tape Machine MIDI Controller to the Ghost MIDI IN.

Other Notes

Closed loop system required.

MMC Open Loop

This allows the Ghost to work with a tape machine which can be controlled using the generic MIDI Machine Control (MMC) protocol and which also sends the timecode as MIDI Timecode (MTC).

Transport Controls

All supported.

Locate To Timecode

Supported.

Record Enable/Rehearse

Not Supported

Jog/Shuttle

Not supported

Setup Notes

See tape machine manual

LTC Timecode (Slave)

The Automation slaves to incoming SMPTE Timecode.

This mode would be used for a tape machine which has no interface for the Ghost to control it, but which has SMPTE Timecode recorded on one track of the Tape Machine.

Transport Controls

Display only, by using timecode values returned by the tape machine. The transport buttons on the console indicate whether timecode is running, stopped etc.

Setup Notes

Connect tape machine SMPTE signal to SMPTE IN on the Ghost.

Akai DR4

Additional Hardware Required

IB-113M-V3.0 MIDI Interface Board

IB-112T-V3.0 SMPTE/EBU Timecode Interface Board (optional)

Transport Controls

All supported, except record.

Locate To Timecode

Supported.

Record Enable/Rehearse

Not supported by the DR4

Jog/Shuttle

Not supported by the DR4

Setup Notes

See the DR4 user documentation.

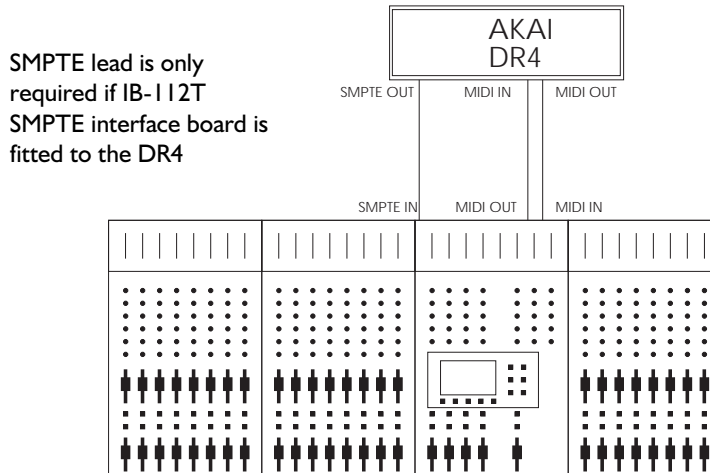

Alesis ADAT (AI-2)

Additional Hardware Required

AI-2 Synchronisation Interface

Transport Controls

All supported, except record. Display tallies created from MTC fed to the Ghost.

Locate To Timecode

Supported.

Record Enable/Rehearse

Not supported by the AI-2

Jog/Shuttle

Not supported by the AI-2

Setup Notes

The following parameters should be set-up on the AI-2 Menus.

Menu	Submenu	Option
Control	Mode	Auto
MIDI	MTC	ON
REFERENCE	Input	IntFix
REFERENCE	GEN	Play/Wind
REFERENCE	GEN STILL	ON

The following diagram shows how to connect the MIDI and sync cables.

Put the AI-2 on-line by pressing its ON-LINE switch.

Other Notes

Open loop control system, uses MMC to control tape machine, may be useful on other 'dumb' machines.

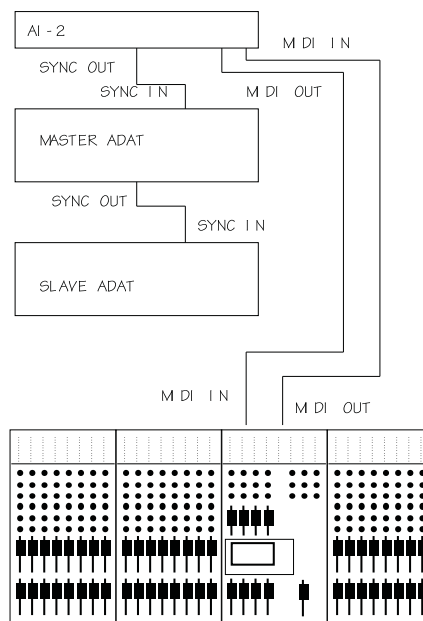

Alesis BRC (MTC)

Transport Controls

All supported, BRC sends back tallies

Locate to timecode

Supported

Record Enable/Rehearse

Supported.

Jog/Shuttle

This function is not supported by Alesis BRC.

Setup Notes

Use the **MIDI/UTIL** button on the BRC to select page 1 on the LCD display

[1. MIDI Echo]

[OFF]

Use the ↑ ↓ keys to select option to **OFF**.

Select page 8

[8. Output Rew/FF]

[SMPTE & MTC **ON**]

Use the ↑ ↓ keys to select option to **ON**.

Select page 9

[9. Sysex Output]

[**Enable**]

Use the ↑ ↓ keys to select option to Enable.

Enable the timecode output using the **GEN SYNC** button on the BRC.

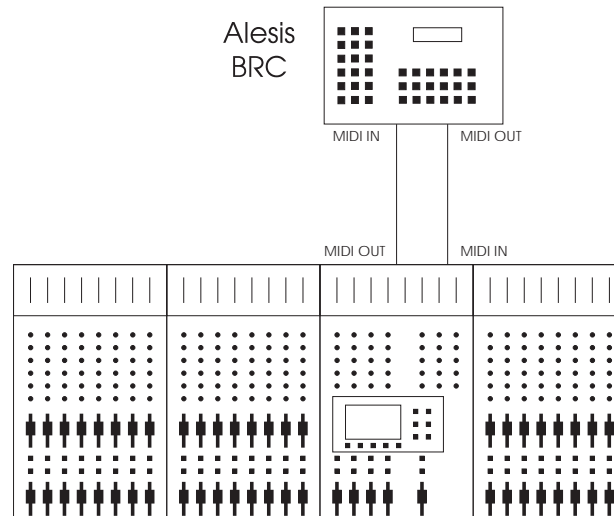

Fostex G series (MIDI)

Additional Hardware Required

G series synchroniser card required, to be fitted to tape machine (Fostex Part no. 8330).

Transport Controls

All supported, machine sends back tallies.

Locate To Timecode

Supported.

Record Enable/Rehearse

Supported.

Jog/Shuttle

Not supported by Fostex G series machines.

Setup Notes

The following procedure should be followed on the front panel of the G24 to set-up the parameters on the synchroniser card.

Hold down **RCL**, while held down press **STO**

Type **60**, use "." to change to **SIO MIDI**.

Press **STO**.

Hold down **RCL**, while held down press **STO**

Type **63**. Type **01**.

Press **STO**.

Hold down **RCL**, while held down press **STO**

Type **64**, use "." to change to **ADFr oF**.

Press **STO**.

Hold down **RCL**, while held down press **STO**

Type **65**, use "." to change to change to **Chuc oF**.

Press **STO**.

Don't forget to connect timecode output from the tape to CODE IN. See diagram below.

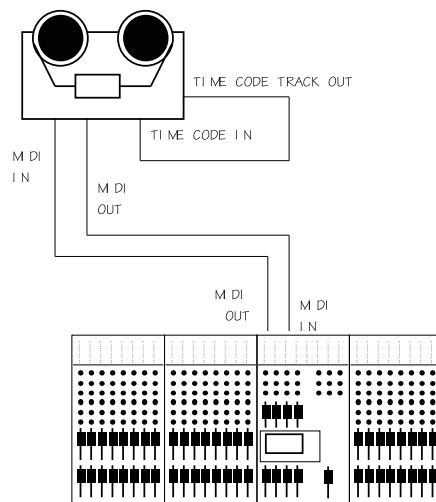

Fostex R series (MIDI)

Additional Hardware Required

Fostex MTC-I Interface (Software version greater than 1.3 required for full functionality)

Transport Controls

All supported, machine sends back tallies

Locate To Timecode

Supported.

Record Enable/Rehearse

Supported. Possible problem with old Fostex exclusive messages on machines earlier than rom revision 1.4.

Jog/Shuttle

Not supported by Fostex R series machines.

Setup Notes

Remember to connect Timecode from tape track to MTC I. See diagram below. Set dipswitch on back to all zeros except switches 8 & 6.

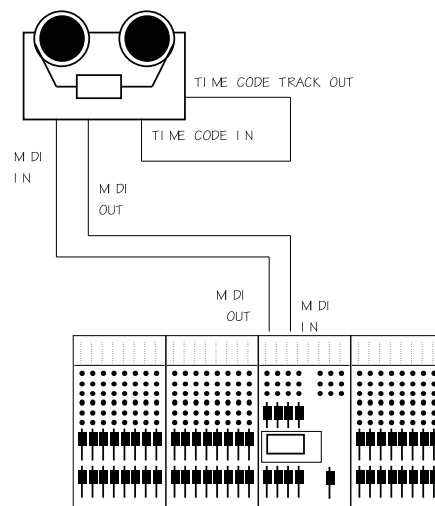

Fostex RD-8 (LTC)(Midi Machine Control)

Transport Controls

All Supported, Tallies generated by LTC.

Locate to Timecode

Supported

Record Enable/Rehearse

This function is supported, but automatic drop-ins are not supported by the Fostex RD-8 using MMC. (RD-8 Software version 1.04).

Jog/Shuttle

This function is not supported by Fostex RD-8.

Setup Notes

Using the buttons on the Fostex RD-8 the following setup is required.

Press button marked **Edit Data** followed by **Remote/Local** then **F3**. This will select **Remote In: Midi**.

Deselect **Edit Data**

Using the **Remote/Local** Button select both modes (RED and GREEN LED on).

Press **Home** button to access the main menu. Using the **Next** button select main menu 3.

Press **F3** to select TCFrame. If the Tape is striped with Timecode then Press \uparrow or \downarrow To select TCOut FR **TAPE**. If the tape has no Timecode on it then Press \uparrow or \downarrow To select TCOut FR 24, 25, 29.97df or 30.

Press **Home** button to access main menu. Using the **Next** button select main menu 4.

Press **F1** to select TCrew. Press \uparrow or \downarrow To select TC REW/FWD to **ON**.

Press **Home** to select Main menu 4. Using the **Next** button select main menu 6. Select MMCOut by pressing **F3**. Press \uparrow or \downarrow To select MMC Output: to **ON**.

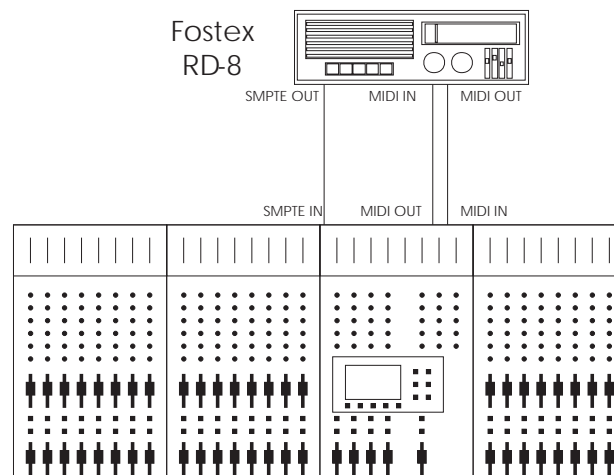

Sony UVW 1800P / DA-88 (LTC)

On selecting this mode, the Tascam DA-88 is put into chase mode and will chase in-coming timecode. The timecode from the Sony VTR is linked to both the timecode input of the DA-88 and the SMPTE in of the Ghost. In this configuration the Ghost sends all transport command to the Sony video machine, but sends record command and the track record enables to the Tascam DA-88.

Additional Hardware Required

SY-88 Card fitted to DA-88.

Ghost to Sony 9 Pin interface cable.

This end connects to Sony 9-Pin Machine		This end connects to Ghost
1	—————	1 Not used
2	—————	2 Rx -
3	—————	3 Tx +
4	—————	4 Not used
5	—————	5 Not used
6	—————	6 Gnd
7	—————	7 Rx +
8	—————	8 Tx -
9	—————	9 Not used
Male 'D-Type'		Female 'D-Type'

Transport Controls

Supported.

Locate to Timecode

Supported.

Record Enable/Rehearse

Record commands not sent to Sony. Command routed to Tascam DA-88.

Jog/Shuttle

Supported.

Setup Notes

For Tascam DA-88 see [TASCAM DA-88 (MTC)]

Sony UWW 1800p (or any Sony 9p machine) must be set to remote.(9 pin remote).

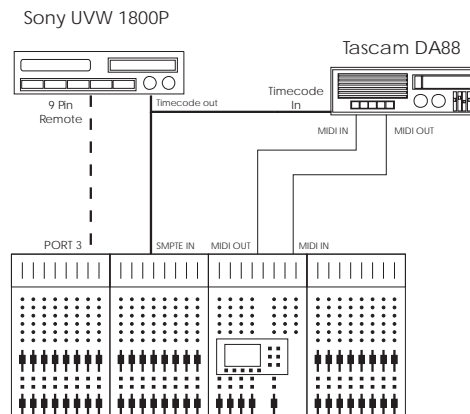

TASCAM DA-88 (LTC)

Additional Hardware Required

SY-88 card fitted to DA-88.

Transport Controls

All supported, machine sends back tallies

Locate To Timecode

Supported.

Record Enable/Rehearse

Only supported on Master machine: the Tascam SY88 card currently only supports a single tape machine for Record Enable/Rehearse, therefore slave machines require manual intervention.

Jog/Shuttle

Not supported by the DA-88 with its current software.

Setup Notes

TIMECODE OUT from the DA-88 should be connected to SMPTE IN on the Ghost. See the diagram below.

Tapes must be formatted before use: this puts ABS-time onto the tape.

You may set the DA-88 to output timecode using the ABS -time or you may put a timecode signal on the tape, in addition to the ABS-time, and use that instead.

Care must be taken in setting up timecode on the DA-88. There are two menus which need to be set correctly. The ABS menu must be set to timecode(P.in = tc) (even if there is no time code on the tape: the locate function will not work otherwise), and the TC menu must be set to whichever code you are going to use (t.out = ABS or t.out = tc). See the Tascam DA-88 and SY-88 manuals for more details.

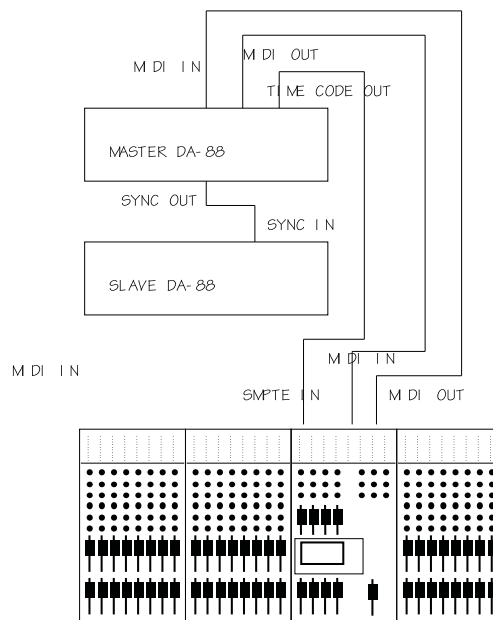

TASCAM DA-88 (MTC)

Additional Hardware required

SY-88 Card fitted to DA-88 (software version 2.03 or better)

Transport Controls

All supported, machine sends back tallies

Locate to Timecode

Supported.

Record Enable/Rehearse

Tascam SY88 card currently only supports a single machine for record Enable/Rehearse, using the Midi machine Control protocol.

Jog/Shuttle

This Function is not supported by Tascam DA-88 via MMC (midi machine control).

Setup Notes

Tape must be formatted before use: this puts ABS-time onto the tape.

SY-88 Switch SI #2: MIDI/9 PIN set to MIDI 0.

You may set the DA-88 to output timecode using the ABS-time or you may put a timecode signal on the tape, in addition to the ABS-time, and use that instead.

Care must be taken in setting up timecode on the DA-88. There are two menus that need to be set correctly. The ABS menu must be set to (P. In = tc)(even if there is no timecode on the tape: the locate function will not work otherwise), and the TC menu must be set to whichever code you are going to use (t. Out = ABS or t. Out = tc). See Tascam DA-88 and SY-88 Manual for more details.

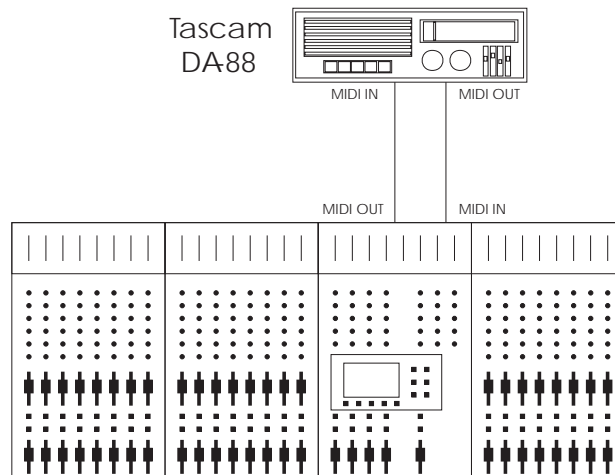

Additional Hardware Required

SY-88 Card fitted to DA-88

(Software version 2,03 or better)

Ghost to Sony 9-pin interface cable.

This end connects to Sony 9-Pin Machine	This end connects to Ghost
1	1 Not used
2	2 Rx -
3	3 Tx +
4	4 Not used
5	5 Not used
6	6 Gnd
7	7 Rx +
8	8 Tx -
9	9 Not used
Male 'D-Type'	Female 'D-Type'

Transport Controls

All supported, machine sends back tallies.

Locate To Timecode

Supported.

Record Enable/Rehearse

This function is supported by Ghost.

Jog/Shuttle

Supported.

Setup Notes

Tape must be formatted before use: this puts ABS-time onto the tape.

SY-88 Switch SI #2: MIDI/9 PIN set to 9 PIN I.

You may set the DA-88 to output timecode using the ABS-time or you may put a timecode signal on the tape, in addition to the ABS-time, and use that instead.

Care must be taken in setting up timecode on the DA-88. There are two menus that need to be set correctly. The ABS menu must be set to (P.in = tc)(even if there is no timecode on the tape: the locate function will not work otherwise), and the TC menu must be set to whichever code you are going to use (t.out = ABS or t.out = Tc).See Tascam DA-88 and SY-88 Manual for more details.

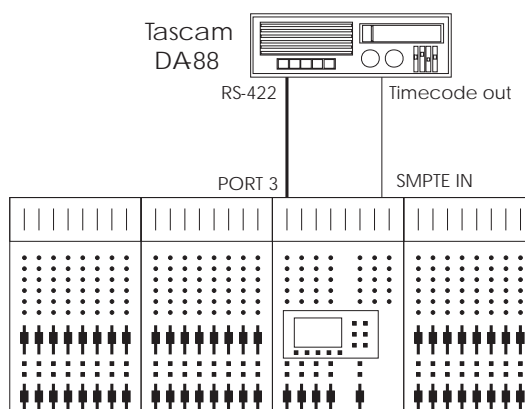

GHOST

Appendix

B

Midi Controller Numbers

Controller Numbers

Controller Number	Controller Function
0	Undefined
1	Modulation wheel or lever
2	Breath Controller
3	Undefined
4	Foot Controller
5	Portamento Time
6	Data Entry MSB
7	Main Volume
8	Balance
9	Undefined
10	Pan
11	Expression Controller
12 - 15	Undefined
16 - 19	General Purpose Controllers (# 1 - 4)
20 - 31	Undefined
32 - 63	LSB for values 0 - 31
64	Damper Pedal (sustain)
65	Portamento
66	Sostenuto
67	Soft Pedal
68	Undefined
69	Hold 2
70 - 79	Undefined
80 - 83	General Purpose Controllers (#s 5 - 8)
84 - 90	Undefined
91	External Effects Depth
92	Tremolo Depth
93	Chorus Depth
94	Celeste (Detune) Depth
95	Phaser Depth
96	Data Increment
97	Data Decrement
98	Non-Registered Parameter Number LSB
99	Non-Registered Parameter Number MSB
100	Registered Parameter Number LSB
101	Registered Parameter Number MSB
102 - 120	Undefined
121 - 127	Reserved for Channel Mode Messages

GHOST

Appendix

C

Midi Note Numbers

MIDI Note Numbers To Mutes Conversion Chart

MIDI Note Number	Ghost Mute Switch	MIDI Note Number	Ghost Mute Switch	MIDI Note Number	Ghost Mute Switch
0	Channel 1 Mute	24	Channel 13 Mute	48	Channel 25 Mute
1	Mix B 1 Mute	25	Mix B 13 Mute	49	Mix B 25 Mute
2	Channel 2 Mute	26	Channel 14 Mute	50	Channel 26 Mute
3	Mix B 2 Mute	27	Mix B 14 Mute	51	Mix B 26 Mute
4	Channel 3 Mute	28	Channel 15 Mute	52	Channel 27 Mute
5	Mix B 3 Mute	29	Mix B 15 Mute	53	Mix B 27 Mute
6	Channel 4 Mute	30	Channel 16 Mute	54	Channel 28 Mute
7	Mix B 4 Mute	31	Mix B 16 Mute	55	Mix B 28 Mute
8	Channel 5 Mute	32	Channel 17 Mute	56	Channel 29 Mute
9	Mix B 5 Mute	33	Mix B 17 Mute	57	Mix B 29 Mute
10	Channel 6 Mute	34	Channel 18 Mute	58	Channel 30 Mute
11	Mix B 6 Mute	35	Mix B 18 Mute	59	Mix B 30 Mute
12	Channel 7 Mute	36	Channel 19 Mute	60	Channel 31 Mute
13	Mix B 7 Mute	37	Mix B 19 Mute	61	Mix B 31 Mute
14	Channel 8 Mute	38	Channel 20 Mute	62	Channel 32 Mute
15	Mix B 8 Mute	39	Mix B 20 Mute	63	Mix B 32 Mute
16	Channel 9 Mute	40	Channel 21 Mute		
17	Mix B 9 Mute	41	Mix B 21 Mute		
18	Channel 10 Mute	42	Channel 22 Mute		
19	Mix B 10 Mute	43	Mix B 22 Mute		
20	Channel 11 Mute	44	Channel 23 Mute		
21	Mix B 11 Mute	45	Mix B 23 Mute		
22	Channel 12 Mute	46	Channel 24 Mute		
23	Mix B 12 Mute	47	Mix B 24 Mute		

MIDI Note Numbers To Expander Mutes Conversion Chart

MIDI Note Number	Expander Mute Switch	MIDI Note Number	Expander Mute Switch
64	Channel 1 Mute	88	Channel 13 Mute
65	Mix B 1 Mute	89	Mix B 13 Mute
66	Channel 2 Mute	90	Channel 14 Mute
67	Mix B 2 Mute	91	Mix B 14 Mute
68	Channel 3 Mute	92	Channel 15 Mute
69	Mix B 3 Mute	93	Mix B 15 Mute
70	Channel 4 Mute	94	Channel 16 Mute
71	Mix B 4 Mute	95	Mix B 16 Mute
72	Channel 5 Mute	96	Channel 17 Mute
73	Mix B 5 Mute	97	Mix B 17 Mute
74	Channel 6 Mute	98	Channel 18 Mute
75	Mix B 6 Mute	99	Mix B 18 Mute
76	Channel 7 Mute	100	Channel 19 Mute
77	Mix B 7 Mute	101	Mix B 19 Mute
78	Channel 8 Mute	102	Channel 20 Mute
79	Mix B 8 Mute	103	Mix B 20 Mute
80	Channel 9 Mute	104	Channel 21 Mute
81	Mix B 9 Mute	105	Mix B 21 Mute
82	Channel 10 Mute	106	Channel 22 Mute
83	Mix B 10 Mute	107	Mix B 22 Mute
84	Channel 11 Mute	108	Channel 23 Mute
85	Mix B 11 Mute	109	Mix B 23 Mute
86	Channel 12 Mute	110	Channel 24 Mute
87	Mix B 12 Mute	111	Mix B 24 Mute

MIDI Note Numbers By Octave

.....

Octave #	Note Numbers											
	C	C#	D	D#	E	F	F#	G	G#	A	A#	B
-1	0	1	2	3	4	5	6	7	8	9	10	11
0	12	13	14	15	16	17	18	19	20	21	22	23
1	24	25	26	27	28	29	30	31	32	33	34	35
2	36	37	38	39	40	41	42	43	44	45	46	47
3	48	49	50	51	52	53	54	55	56	57	58	59
4	60	61	62	63	64	65	66	67	68	69	70	71
5	72	73	74	75	76	77	78	79	80	81	82	83
6	84	85	86	87	88	89	90	91	92	93	94	95
7	96	97	98	99	100	101	102	103	104	105	106	107
8	108	109	110	111	112	113	114	115	116	117	118	119
9	120	121	122	123	124	125	126	127				

GHOST

Appendix

D

MIDI Implementation Chart

GHOST MIDI Implementation Chart

Function		Transmitted	Recognised	Remarks
Basic Channel	Default	1	1	
	Changed	1-16	1-16	
Mode	Default	MODE3	MODE3	
	Messages	X	X	
	Altered	X	X	
Note Number:		0-111	0-111	See Note 1
	True Voice	X	X	
Velocity	Note On	X	X	Note ON. Velocity 127 = Channel not muted Note ON. Velocity 1 = Channel muted
After Touch	Keys	X	X	
	Chs	X	X	
Pitch Bend		X	X	
Control Change		O	X	As programmed when the data fader is moved
Program Change		0 - 127	0 - 127	See Note 2
	True#	X	X	
System Exclusive		O	O	See Note 3
System Common	Song Position	X	X	
	Song Select	X	X	
	Tune	X	X	
System Real Time	Clock	X	X	
	Command	X	X	
Aux Messages	Local On/Off	X	X	
	All Notes Off	X	X	
	Active Sense	X	X	
	Reset	X	X	
Notes		<p>Note 1. Note Numbers 24 Channel Console Main Channel Mute 1 = 0, Mix B Mute 1 = 1 Main Channel Mute 24 = 46, Mix B Mute 24 = 47 32 Channel Console Main Channel Mute 1 = 0, Mix B Mute 1 = 1 Main Channel Mute 32 = 62, Mix B Mute 32 = 63 24 Channel Expander Main Channel Mute 1 = 64, Mix B Mute 1 = 65 Main Channel Mute 32 = 110, Mix B Mute 32 = 111</p> <p>Note 2. Program Change Program Change Numbers 0 - 127 are transmitted when scenes 1 - 128 are recalled. When Program change Numbers 0 - 127 are received, scenes 1 - 128 are recalled.</p> <p>Note 3. System Exclusive. The system exclusive file format used to dump the scenes to an external computer for backup purposes is as follows: Header: f0 39 7f 07 01 39 'MIDI' 00 00 03 04 f7 Start Packet: f0 39 7f 07 02 00 17 'Soundcraft GHOST' <Version no> f7 Data packets containing scenes: f0 39 7f 07 02 <Packet count> <data size> <data> <checksum> f7 End of file: f0 39 7f 7b 00 f7 (Where '...' indicates ASCII code for text, & '<...>' indicates hexadecimal data)</p>		
Mode 1: OMNI ON, POLY Mode 3: OMNI OFF, POLY		Mode 2: OMNI ON, MONO Mode 4: OMNI OFF, MONO		O: Yes X: No

GHOST

Appendix

E

Upgrading The Software

Upgrading The Software

From time to time Soundcraft may make available new software releases for Ghost. This may be in response to user feedback, or for bug fixes. The operating software is stored in internal flash-RAM, and has to be loaded using an external PC or Apple Mac computer. The serial port of the computer is connected to the Ghosts 9-pin port which can be switched to accept the software download. The program file which contains the consoles operating system is available on our Internet Web site (<http://www.soundcraft.com>) under the Product Support section, or from your local Soundcraft dealer or Distributor in the form of a 3.5" floppy disk.

If you have a Apple Mac computer, you will also need to obtain a serial communications program (we recommend ZTerm) which are available as shareware from the Internet or an Apple software supplier. If you do not have a PC or Mac, please contact your local Soundcraft dealer for advice.

The following pages give instructions for downloading new software from the following types of computer:

- PC running Windows 3.1/3.11
- PC running Windows 95
- Apple Mac with ZTerm and PC Exchange installed.
- Download Cable Details

You will need to make up a special interface cable (referred to in these instructions as the Download Cable) to connect the Ghost to the PC or Mac. The cable connects from the Sony 9-pin port on the Ghost to the serial port or modem port of the computer. The wiring information for these cables is shown below (they are also available ready made, the part numbers are, Ghost/PC RV3541 and Ghost/Mac RV3691) :

(Note: All connectors shown below are viewed from the solder side).

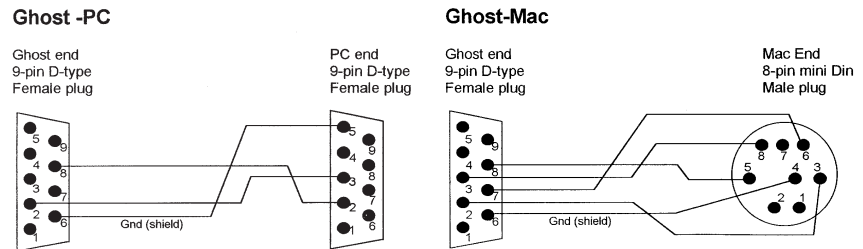

Software Download from PC running Windows 3.1/3.11

Start Windows and run the Terminal program, usually located in Accessories group. Ensure the settings are correct, by choosing the Settings menu and selecting the Communications option. The settings should be as follows:

```
bits per sec:    19200
data bits:      8
parity:         none
Stop bits:      1
Flow control:   None
```

Locate the Ghost software program file (Ghost.abs) either on floppy disk or from the Internet. In the latter case, save the file in a known location (do not change the filename!).

Switch off the Ghost console and connect the download cable (9-pin to 9-pin D-type, see above for pin-out). from the Com 1 port on the PC to the 9-pin socket on the Ghost rear panel.

Using a thin implement, push in and latch the hidden download switch on the Ghost. This is accessible via a small hole in the rear panel, next to the 9-pin socket.

Switch on the Ghost console. The console will not boot up as usual, but will either display nothing on the timecode display, or all 8s, together with other flashing lights on the CPU section -this is normal! A menu will be displayed on the Terminal screen, as follows:

```
Boot code Version 1.00
? - display this help
e - erase flash program memory
x - initiate XMODEM transfer
i - diagnostic info
```

Press the “e” key on the PC; the screen will indicate that the flash memory is erasing. (This will not erase the Ghosts snapshots and midi setup).

When the message done, press the “x” key to initiate the software download.

Open the Transfer menu and select Send Binary File.

Select the Ghost.abs file in the filename field, from the floppy drive or wherever you put it on the hard drive.

The file transfer will now start, with a message at the bottom of the screen informing you of the progress. (Note: if you take too long finding and selecting the Ghost.abs file after pressing the “x” key, the Ghost may time-out, with the message “transfer unsuccessful”. If this happens, power down the Ghost and power up again to obtain the menu, then press “x” again and try again).

When the transfer is complete (it will take several minutes), the message “Transfer done!” will appear. Turn off the Ghost console, disconnect the download cable and unlatch the recessed download switch on the back of the console.

Power up the Ghost -the console should now boot up as normal, with the new software version number displayed during the boot-up.

On the PC, exit the Terminal program, and choose “Yes” when prompted to save the session. This will save the settings you chose at the beginning of the procedure, for future use.

Software Download from PC Running Windows 95

From the Start menu choose Programs, then Accessories, then Hyperterminal. Double-click the Hypertrm icon to open this program.

Enter the name "Ghost Download" and choose an icon then click OK. This will enable you to return to the program easily on subsequent occasions with the correct parameter already setup for Ghost.

You will now get the phone number dialogue box. Leave the phone number field blank, and set the connect using... parameter to "direct to Com 1" (or whichever serial port is accessible on the back of the PC)

You now get the Com 1 Properties dialogue box. Set up the parameters as follows:

bits per sec:	19200
data bits:	8
parity:	none
Stop bits:	1
Flow control:	None

Click OK. The blank Hyperterminal screen will now be displayed.

Locate the Ghost software program file (Ghost.abs) either on the floppy disk or from the internet. In the latter case, save the file in a known location (do not change the filename!).

Switch off the Ghost console and connect the download cable (9-pin to 9-pin D-type, see above for pin-out) from the Com 1 port on the PC to the 9-pin socket on the Ghost rear panel.

Using a thin implement, push in and latch the hidden download switch on the Ghost. This is accessible via a small hole in the rear panel, next to the 9-pin socket.

Turn on the Ghost console. The console will not boot up as usual, but will either display nothing on the timecode display, or all 8s, together with other flashing lights on the CPU section -this is normal! A menu will now appear on the Hyperterminal screen :

```
Boot code Version 1.00
? - display this help
e - erase flash program memory
x - initiate XMODEM transfer
l - diagnostic info
```

Press the "e" key on the PC; the screen will indicate that the flash memory is erasing. (This will not erase the Ghosts snapshots and midi setup).

When the message "done", press the "x" key to initiate the software download.

In Hyperterminal, open the Transfer menu and select Send File.

Select the Ghost.abs file in the filename field, from the floppy drive or wherever you put it on the hard drive. Set the Protocol to X-Modem and click Send.

The file transfer will now start, with a dialogue box entitled File send for Ghost Download informing you of the progress. (Note: if you take too long finding and selecting the Ghost.abs file after pressing the "x" key, the Ghost may time-out, with the message "transfer unsuccessful". If this happens, power down the Ghost and power up again to obtain the menu, then press "x" again and try again).

When the transfer is complete (it will take several minutes), the message "Transfer done!" will appear. Turn off the Ghost console, disconnect the download cable and unlatch the recessed download switch on the back of the console.

Power up the Ghost -the console should now boot up as normal, with the new software version number displayed during the boot-up.

On the PC, exit the Hyperterminal program, and choose "Yes" when prompted to save the session. This will give you the icon you chose at the beginning of the procedure, in the Hyperterminal window, for future use.

Software Download from Apple Mac

Make sure that you have the following programs loaded on you Mac: (They do not always come as standard, so you may have to contact your Apple dealer for help, or download the applications from a suitable Internet FTP site -e.g. sumex mirrors, mac.archive.umich.edu, or on CompuServe: Mac Communication Forum).

- PC Exchange
- ZTerm or another serial comms program. The instructions below refer to ZTerm.

Procedure

Launch ZTerm from your desktop. From the Settings menu, choose Connection. You will now have a dialogue box displaying the terminal settings. Set these up as follows:

Data Rate:	19200
Data Bits:	8
Parity:	None
Local echo:	off
Flow Control:	off
Hardware handshake:	off

From the Settings menu, choose Transfer Options.

In the Transfer Options dialogue box, set up as follows:

Send:	Xmodem
Receive:	Xmodem

From the Settings menu, choose Modem Preferences. Check that this is set up as follows:

Serial Port = modem port

You should now have a blank terminal screen, set up with the necessary parameters.

Locate the Ghost.abs program file, either on PC format floppy disk, or from the Internet. In the latter case, save the file in a known location (do not change the filename!). In the case of the floppy disk, if PC Exchange software is loaded, the disk can be read by the Mac and will appear on the desktop in the normal way.

Switch off the Ghost console and connect the download cable (8-pin mini-DIN to 9-pin D-type, see above for pin-out) from the Modem port on the Mac to the 9-pin socket on the Ghost rear panel.

Using a thin implement, push in and latch the hidden download switch on the Ghost. This is accessible via a small hole in the rear panel, next to the 9-pin socket.

Turn on the Ghost console. The console will not boot up as usual, but will either display nothing on the timecode display, or all 8s, together with other flashing lights on the CPU section - this is normal! A menu will now appear on the Macs ZTerm screen :

```
Boot code Version 1.00
? - display this help
e - erase flash program memory
x - initiate XMODEM transfer
l - diagnostic info
```

Press the "e" key on the Mac; the screen will indicate that the Ghosts flash memory is erasing. (This will not erase the Ghosts snapshots and midi setup).

When the message "done" appears, press the "x" key to initiate the software download. (The message "Please start XMODEM transfer now" will be displayed on the screen).

From the File menu choose Send X-modem. This gives you a menu which allows the required file to be selected. Select the Ghost.abs file from wherever you put it on the floppy or hard drive. Click Open. A dialogue box will now appear to show the progress of the download.

(Note: if you take too long finding and selecting the Ghost.abs file after pressing the “x” key, the Ghost may time-out, with the message “transfer unsuccessful”. If this happens, power down the Ghost and power up again to obtain the menu, then press “x” again and try again).

When the transfer is complete (it will take several minutes), the message “Transfer done!” will appear. Turn off the Ghost console, disconnect the download cable and unlatch the recessed download switch on the back of the console.

Power up the Ghost -the console should now boot up as normal, with the new software version number displayed during the boot-up.

Exit ZTerm on the Mac and close down.

Software Download Troubleshooting

A. When I switch on the console, the download menu does not appear.

Check that the download lead is firmly connected the correct way around. Check that the Download switch on the back of Ghost is latched in. Check that the Terminal setup options are correct.

B. When I switch on the console, spurious characters appear.

Check that the download is connected the correct way around. Check that the Terminal setup options are correct.

C. The words "Bad command appear" every time I press a key.

Check that Caps Lock is not on.

D. After pressing "x" and sending the file using the Terminal program, the download does not seem to work.

Cancel the download from Terminal program.

Switch off the Ghost console, then switch back on.

Begin the transfer again.

(Downloads can be temperamental, and may need several attempts!)

